

# NESTOR MARTIN

## THS15 & FHS15



### INSTALLATION, SERVICING AND USER INSTRUCTIONS

For use in GB & IE (United Kingdom and Ireland)

This appliance has been tested and certified for other counties (see technical data). However to install appliance in other countries, modification of the appliance and its method of installation may be necessary in order to use the appliance safely and correctly. The manual for the local language must be obtained. Contact Nestor Martin for further information.

This Manual covers the following Products:

THS15 Nestor Martin  
FHS15 Nestor Martin

---

## Content

1. General Notes	4
2. User instructions.	5
2.1 <i>Emergency Gas Isolation</i>	5
2.2 <i>First Time of Operation</i>	5
2.3 <i>Control Overview</i>	6
2.4 <i>Manual Turn OFF</i>	11
2.5 <i>Cleaning and Maintenance</i>	11
3. Installation instructions.	12
3.1 <i>Gas Connection</i>	12
3.2 <i>Ventilation</i>	12
3.3 <i>Appliance installation</i>	12
3.4 <i>Flue Connection</i>	13
3.5 <i>Fuel Bed Arrangements</i>	17
3.6 <i>Commissioning the appliance</i>	23
4. Servicing	24
4.1 <i>Cleaning the Ceramics</i>	24
4.2 <i>Servicing the Burners</i>	24
4.3 <i>Spare parts</i>	24
5. Technical Information	25
5.1 <i>Countries of Use</i>	25
5.2 <i>Technical Data</i>	26
5.3 <i>Dimensions</i>	27
Appendix	28
Appendix 1 – <i>Mertik Fault Finding Chart</i>	28

## 1. General Notes

This Nestor Martin gas appliance is a High Efficiency, Balanced Flue Live Fuel Effect appliance. It provides radiant and convected heat using the latest burner technology..

Before Installation, check that the local distribution conditions, nature of the gas and pressure, and adjustment of the appliance are compatible.

This appliance is intended for use on a gas installation with a governed meter.

This Gas Installation **may only be installed by a registered professional competent person (Gas Safe installer in the UK)**. The installation must adhere to the requirements of the local and national Building regulations and national standards. The installation manual must also be followed.

Ensure that the Flue Terminal is not in any way obstructed and is clear of vegetation, i.e. trees, shrubs etc. and that no objects are leant against the terminal or guard.

Always clean the Window Panel before the fire is ignited. Any finger prints must be removed, as these will be burnt into the glass and will be un-removable.

Do not operate this appliance if the glass panel has been broken (or cracked), removed or with firebox access panels open.

Only flue approved by Nestor Martin for this appliance may be used.

This appliance is a balanced flue product and is room sealed and as such requires no additional ventilation for operation. However an adequate supply of fresh air to maintain temperatures and a comfortable environment is recommended.

This appliance is designed as a heating appliance, and as such will get very hot in operation; all surfaces (except the controls and access door) are considered to be working surfaces and as such should not be touched. The front windows and surrounds are not considered to be fully secure guards against accidental contact. It is recommended that an approved fire screen be used if children, the elderly or persons with limited mobility are to be present in the same area.

Do not place curtains, laundry, furniture etc. within a safe distance of 300mm of this appliance.

Do not attempt to burn rubbish on this appliance.

If this appliance is extinguished, on purpose or other, no attempt to relight should be made within 3 minutes.

## 2. User instructions.

### 2.1 Emergency Gas Isolation

In the event of a gas leak or if gas is smelt, the appliance must be isolated. This is done by turning OFF the gas at the Isolation Tap. This Isolation Tap is located in the foot of the appliance.

### 2.2 First Time of Operation

Before igniting the appliance, ensure that all packaging, safety stickers and any protective wrapping have been removed, and that the glass has been cleaned, including all fingerprints from the glass.

Ensure that the room is adequately ventilated the first time that the appliance is ignited; we would recommend opening windows if possible. Run the appliance at full setting for a few hours so that the paint gets an opportunity to fully cure. During this period it is possible for some fumes and vapours to be given off. We would recommend keeping children and pets out of the area at this time.



fig. 1.1 Remote Handset

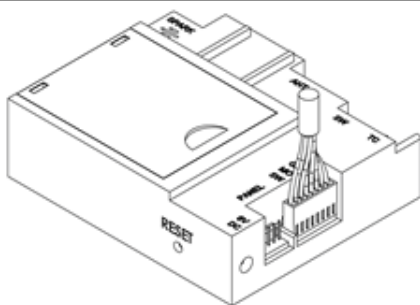

fig. 1.2 Remote Receiver

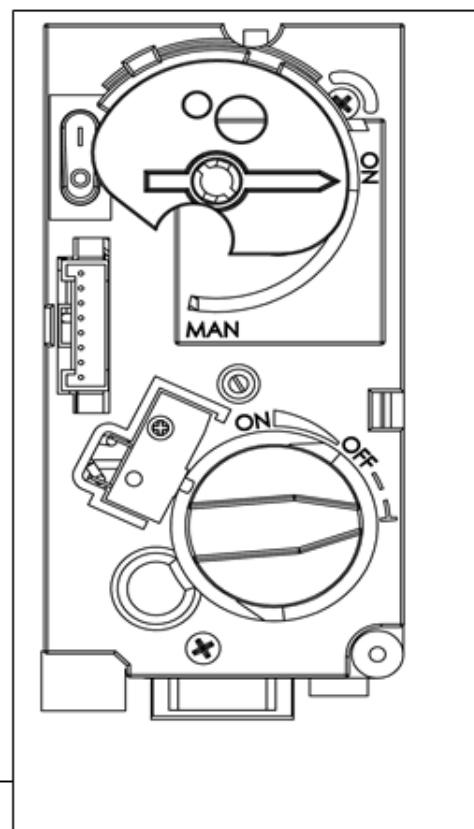

fig. 1.3 Gas Control Valve

## 2.3 Control overview

### 2.3.1 : reset electronic code

Important : reset electronic code to synchronize receiver and handset (first use)

Add battery in the handset (2 x AAA) and in the receiver (4 x AA).

With a sharp object, press on reset (picture 1) until you hear 2 bips (first a short one and after a long one). Now you can take the handset and press on button **A** (see picture 2) until you hear 2 short bips. Now the receiver and the handset are synchronized

### 2.3.2 Remote Control



Picture 1



Picture 2

A

#### INFORMATION

The gas block and receiver wiring must be completed before starting the ignition. Any non-compliance can damage the electronic components.

#### batteries - remote control

- Battery indicator discharged on remote controls with display.

#### receiver batteries

- Low battery indication: frequent beep for 3 seconds when the engine is running.
- A main adapter can be used instead of the batteries.
- The fan speed control module and the lighting / dimmer together provide a main power supply with batteries in the automatic reserve in the event of a power failure.

#### WARNING !

- Sans utiliser d'adaptateur, le remplacement de la pile est recommandé au début de chaque saison de chauffage.
- Retirer immédiatement les batteries usagées ou déchargées. Les batteries restant dans l'unité peuvent surchauffer, fuir et/ ou exploser.
- Ne PAS exposer les batteries aux rayons directs du soleil, à une chaleur excessive, au feu, à l'humidité ou à des chocs violents (y compris pendant leur stockage). Les batteries risquent en effet de surchauffer, de fuir et/ou d'exploser.
- Ne pas utiliser conjointement des batteries usagées et nouvelles et différentes marques de batteries car il y a un risque de surchauffe, de fuite et/ou d'explosion.

**SYMBOL**

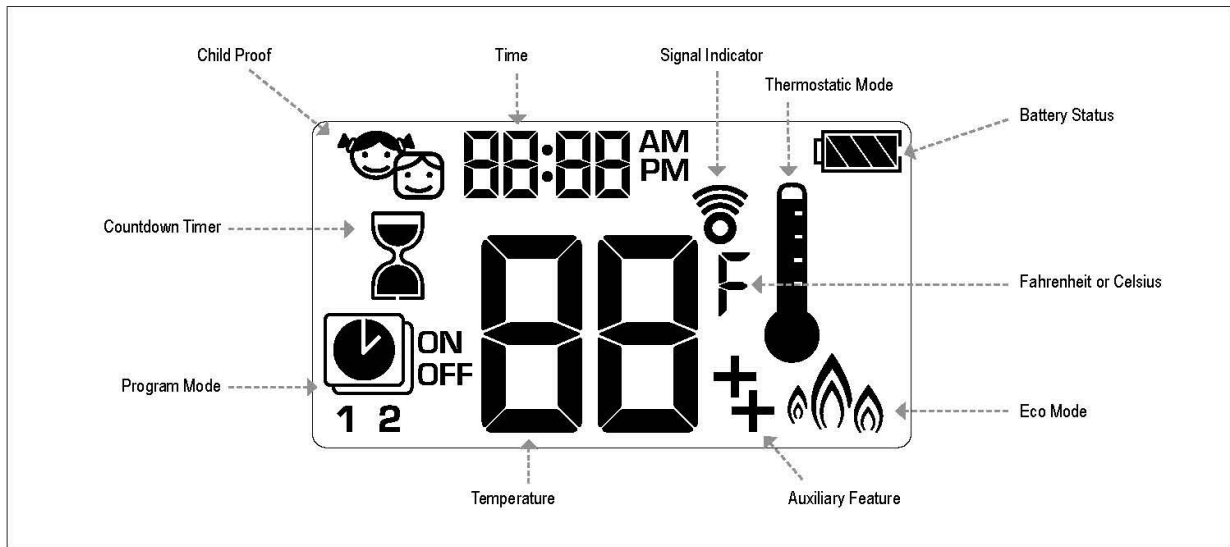
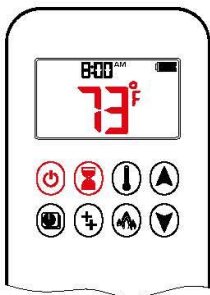

Figure 28: 8-symbol Display

**SETTING FAHRENHEIT or CELSIUS**



To change between °C and °F, press and buttons simultaneously.

**NOTE:** Choosing °F results in a 12 hour clock. Choosing °C results in a 24 hour clock.

**CHILD PROOF**



**ON:**  
To activate press and buttons simultaneously. displayed and the handset is rendered inoperable, except for the off function.

**OFF:**  
To deactivate press and buttons simultaneously. disappears.

**SETTING the TIME**

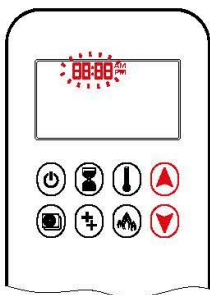

1. Press and buttons simultaneously. **Day** flashes.
2. Press or button to select a number to correspond with the day of the week (e.g. 1=Monday, 2=Tuesday, 3=Wednesday, 4=Thursday, 5=Friday, 6=Saturday, 7=Sunday).
3. Press and buttons simultaneously. **Hour** flashes.
4. To select hour press or button.
5. Press and buttons simultaneously. **Minutes** flash.
6. To select minutes press or button.
7. To confirm press and buttons simultaneously or wait.

**MANUAL MODE (HANDSET)**

**NOTICE**

BEFORE OPERATING



1. Make sure MANUAL knob on the GV60 valve is in the ON, full counterclockwise  position.
2. Place the ON/OFF switch (if equipped) in the I (ON) position.

**TO TURN ON FIRE**

**▲ WARNING**

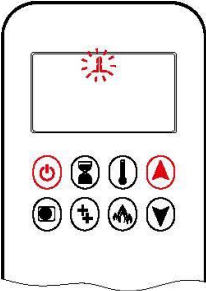
When pilot ignition is confirmed, motor turns automatically to maximum flame height.



- Press  button (One Button Ignition) or  and  button simultaneously (Two Button Ignition) until two short beeps and a blinking series of lines confirms the start sequence has begun; release button(s).
- Main gas flows once pilot ignition is confirmed.
- Handset automatically goes into Manual Mode after main burner ignition.

**▲ WARNING**

If the pilot does not stay lit after several tries, turn the main valve knob to OFF and follow the instructions "TO TURN OFF GAS TO APPLIANCE" (page 33).

**STANDBY MODE (PILOT FLAME)**

**Handset**

- Press and hold  button to set appliance to pilot flame.

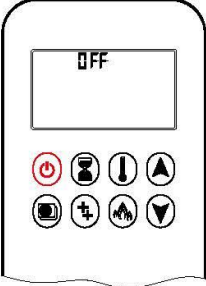

**TO TURN OFF FIRE**



- Handset**
- Press  button to turn OFF.
- NOTE:** A new ignition is possible after the OFF icon stops flashing.

**FLAME HEIGHT ADJUSTMENT**



- Handset**
- To increase flame height press and hold  button.
  - To decrease flame height or to set appliance to pilot flame, press and hold  button.

**DESIGNATED LOW FIRE and HIGH FIRE**

**NOTE:** Backlight must be on for high fire and low fire double-click operation.

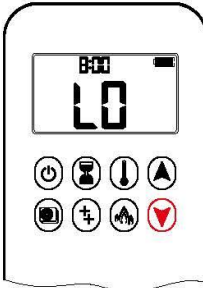

- To go to low fire, double-click  button. **LO** is displayed.
- NOTE:** Flame goes to high fire first before going to low fire.

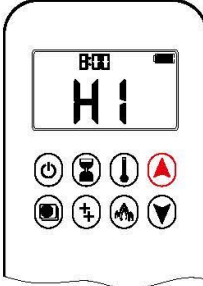

- To go to high fire, double-click  button. **HI** is displayed.

**▲ WARNING**

If the appliance will not operate, follow the instructions "TO TURN OFF GAS TO APPLIANCE" (page 33).

**COUNTDOWN TIMER**

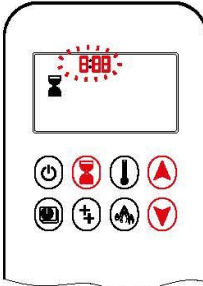

- ON/SETTING:**
1. Press and hold  button until  displayed, and **hour** flashes.
  2. To select hour press  or  button.
  3. To confirm press  button. **Minutes** flash.
  4. To select minutes press  or  button.
  5. To confirm press  button or wait.

**OFF:**

Press  button,  and countdown time disappear.

**NOTE:** At end of countdown time period, the fire shuts off. The Countdown Timer only works in Manual, Thermostatic, and Eco Modes. Maximum countdown time is 9 hours and 50 minutes.



**MODES of OPERATION**



**Thermostatic Mode**  
The room temperature is measured and compared to the set temperature. The flame height is then automatically adjusted to achieve the set temperature.

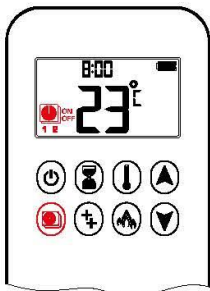

**Program Mode**  
PROGRAMS 1 and 2, each can be programmed to go on and off at specific times at a set temperature.



**Eco Mode**  
Flame height modulates between high and low. If the room temperature is lower than the set temperature, the flame height stays on high for a longer period of time. If the room temperature is higher than the set temperature, the flame height stays on low for a longer period of time. One cycle lasts approx. 20min.

**THERMOSTATIC MODE**



**ON:**  
Press **↓** button. **↓** displayed, preset temperature displayed briefly, and then room temperature displayed.

**OFF:**  
1. Press **↓** button.  
2. Press **▲** or **▼** button to enter Manual Mode.  
3. Press **☼** button to enter Program Mode.  
4. Press **🔥** button to enter Eco Mode.



**SETTING:**  
1. Press **↓** button and hold until **↓** displayed, temperature flashes.  
2. To adjust set temperature press **▲** or **▼** button.  
3. To confirm press **↓** button or wait.

**PROGRAM MODE**

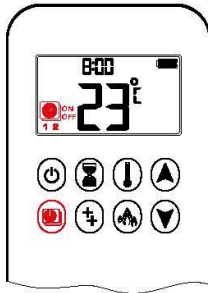

**ON:**  
Press **☼** button. **☼**, **1** or **2**, **ON** or **OFF** displayed.

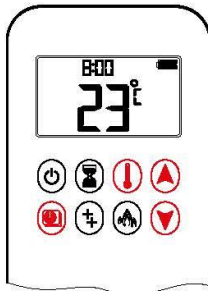

**OFF:**  
1. Press **☼** or **▲** or **▼** button to enter Manual Mode.  
2. Press **↓** button to enter Thermostatic Mode.

**NOTE:** The set temperature for Thermostatic Mode is the temperature for the on time in Program Mode. Changing the Thermostatic Mode set temperature also changes the on time temperature in Program Mode.

**Default settings:**  
ON TIME (Thermostatic) TEMPERATURE: 70 °F/21 °C  
OFF TIME TEMPERATURE: "—" (pilot flame only)

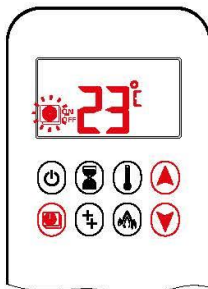

**TEMPERATURE SETTING:**  
1. Press **☼** button and hold until **☼** flashes. **ON** and set temperature (setting in Thermostatic Mode) displayed.  
2. To continue press **☼** button or wait. **☼**, **OFF** displayed, temperature flashes.  
3. Select off temperature by pressing the **▲** or **▼** button.  
4. To confirm press **☼** button.

**NOTE:** The on (Thermostatic) and off set temperatures are the same for each day.

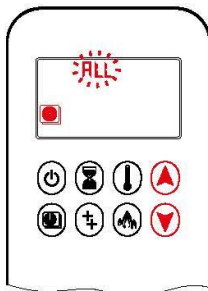

**DAY SETTING:**  
5. **ALL** flashes. Press **▲** or **▼** button to choose between **ALL**, **SAT**, **1**, **2**, **3**, **4**, **5**, **6**, **7**.  
6. To confirm press **☼** button.

**RLL selected**

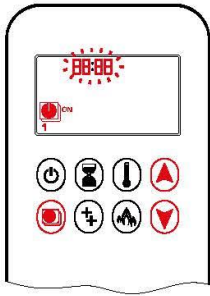

- ON TIME SETTING (PROGRAM 1):
7. **1 ON** displayed, **RLL** is displayed shortly, and **hour** flashes.
  8. To select hour press **▲** or **▼** button.
  9. To confirm press **⊙** button. **1 ON** displayed, **RLL** displayed shortly, and **minutes** flash.
  10. To select minutes press **▲** or **▼** button.
  11. To confirm press **⊙** button.



- OFF TIME SETTING (PROGRAM 1):
12. **1 OFF** displayed, **RLL** is displayed shortly, and **hour** flashes.
  13. To select hour, press **▲** or **▼** button.
  14. To confirm press **⊙** button. **1 OFF** displayed, **RLL** displayed shortly, and **minutes** flash.
  15. To select minutes press **▲** or **▼** button.
  16. To confirm press **⊙** button.

**NOTE:** Either continue to PROGRAM 2 and set on and off times or stop programming at this point, and PROGRAM 2 remains deactivated.

**NOTE:** PROGRAM 1 and 2 use the same on (Thermostatic) and off temperatures for **RLL**, **SRSU** and Daily Timer (1, 2, 3, 4, 5, 6, 7). Once a new on (Thermostatic) and/or off temperature has been set, that temperature becomes the new default setting.

**NOTE:** If **RLL**, **SRSU** or Daily Timer are programmed for PROGRAM 1 and PROGRAM 2 on and off times, these become the new default times. The batteries must be removed to clear the PROGRAM 1 and PROGRAM 2 on and off times and temperatures.

**SRSU or Daily Timer (1, 2, 3, 4, 5, 6, 7) selected**

- Set on time and off time using same procedure as "RLL selected" (above).
- **SRSU:** Set on time and off time for both Saturday and Sunday.
- Daily Timer: Unique on and off times may be set for a single day of the week, for multiple days of the week, or for every day of the week.
- Wait to finish setting.

**AUXILIARY FEATURE (2ND BURNER FEATURE)**

The latching solenoid valve will open automatically after ignition or after switching the system off, so that the maximum flow of gas is supplied to both burners assisting with the ignition process. After pressing the AUX-Button the motor will turn 7 seconds in the ON direction until the max. position is reached.



**ON:**  
To switch a burner on, press the **⊕** button. **⊕** displayed.

**OFF:**  
To switch the burner OFF, press the **⊖** button. **⊕** disappears.

**NOTE:** The latching solenoid valve cannot operate manually. If the receiver battery runs down it will remain in the last operating position.

**ECO MODE**

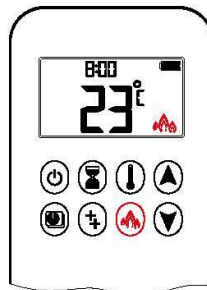

**ON:**  
Press **🔥** button to enter Eco Mode. **🔥** displayed.

**OFF:**  
Press **🔥** button. **🔥** disappears.

**MYFIRE APP**

**NOTICE**

Before the App can be used, the myfire Wi-Fi Box must be wired and plugged into mains power according to myfire App setup diagram (see figure 20, page 12), and the App setup must be completed (see myfire App setup, page 15).



If Thermostatic, Program or Eco Mode is activated, the corresponding icon and "APP" is displayed on the handset.

The modes can be operated according to the descriptions on previous pages.

**NOTE:** In Manual Mode "APP" is NOT displayed on the handset.

## 2.4 Manual Turn OFF

In the event that the appliance needs to be turned OFF manually, for instance, if the remote control is lost or the batteries become totally flat, the control valve must be accessed and the switch flipped to OFF (marked "0").

The picture below shows the control valve.

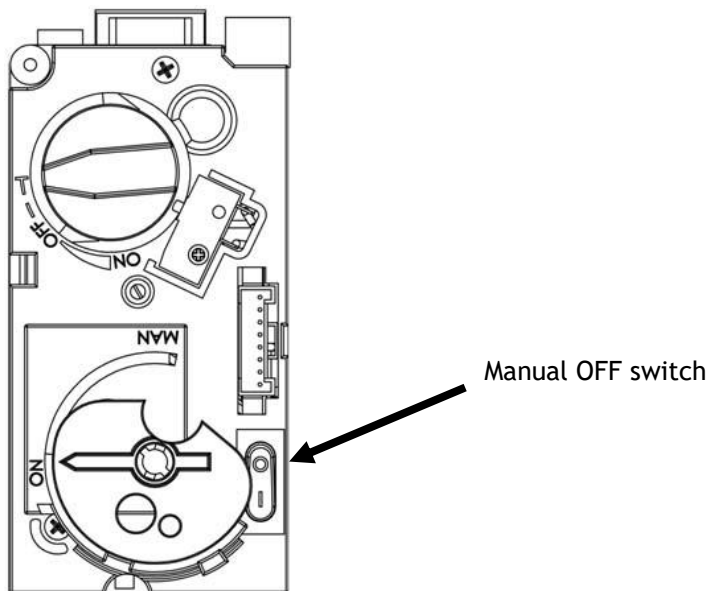

The control valve is located behind the control hatch in the Base of the appliance.

## 2.5 Cleaning and Maintenance

This appliance should be inspected and serviced once a year by a qualified, competent and registered person. The inspection and maintenance must at least ensure that the appliance is working correctly and safely. It is advisable to clean the appliance of any dust and debris before regularly during the heating season and especially if the appliance has not been used for some time. This can be done with a soft brush and a vacuum cleaner or a damp cloth and if required a non-abrasive cleaning agent. Do not use corrosive or abrasive substances to clean the appliance.

### 3. Installation instructions.

Before commencing Installation, confirm that the details on the appliance data plate correspond to the local distribution conditions, gas type and pressure to which the appliance is to be installed.

Ensure that gas supply and supply pipe is capable of delivering the required volume and pressure of gas and is in accordance with the rules in force.

#### 3.1 Gas Connection

This appliance has a gas inlet connection of Ø 8mm.

#### 3.2 Ventilation

This appliance is a Balanced Flue room sealed appliance, and as such needs no additional ventilation. However an adequate supply of fresh air to maintain temperatures and a comfortable environment is recommended.

This appliance may be installed in a completely sealed or mechanically ventilated house.

#### 3.3 Appliance Installation

Determine the position required for the appliance.

Create a gas connection for the appliance in approximately the correct location for the gas controls.

The gas controls are connected to the Burner of the appliance.

Do not make any adjustments to the appliance.

The Flue system should be fitted with a minimum clearance of 25mm from any combustible objects or materials; this includes any combustible materials used for the fireplace construction.

As this is a room sealed appliance and the appliance stands appropriately and is securely fixed to the floor, a hearth is not required for this appliance.

A minimal gap of 50mm should be left all round the appliance to non-combustible materials.

For minimum clearance of 200mm to combustible materials should be left all round the appliance.

## 3.4 Flue Connection

### 3.4.1 General notes

This appliance may be installed with a roof terminal (C31) or a wall terminal (C11).

This appliance may only be used with Balanced Flue (otherwise known as Concentric Flue) parts as specified by Don-Bar. The Nestor Martin specified flue parts have been approved with the appliance. If the appliance is installed on non-Nestor Martin approved parts, Nestor Martin cannot guarantee or accept and responsibility for the proper and safe working of the appliance.

The flue system must be constructed from the appliance upwards, with all joints being fully locked and sealed using the Nestor Martin specified parts.

### 3.4.2 Timber Frame Construction

Whilst it is possible to install room-sealed appliances in timber frame properties, great care needs to be taken to ensure that the flue assembly does not interfere with the weather proofing qualities of any outer wall which it may penetrate. Before attempting this work, further details need to be referenced, (e.g. "Gas Installations in Timber Frame Buildings" from the CORGI installer series in the UK).

### 3.4.3 Carport or Building Extension

Where a flue terminal is sited within a carport or building extension, it should have at least two completely open and unobstructed sides. The distance between the lowest part of the roof and the top of the terminal should be at least 600mm.

*Note: A covered passageway should not be treated as a carport.* Flues should not be sited in a covered passageway between properties.

### 3.4.4 Basements, Lightwells and Retaining walls

Flue terminals should not be sited within the confines of a basement area, light well or external space formed by a retaining wall, unless steps are taken to ensure the products of combustion can disperse safely at all times. It may be possible to install this Balanced Flue system in such a location provided that it is not sited lower than 1m from the top level of that area to allow combustion products to disperse safely.

Flue terminals should be sited to ensure total clearance of the combustion products in accordance with the included information.

When the products of combustion are discharged, they should not cause a nuisance to adjoining or adjacent properties and they should be positioned so that damage cannot occur to other parts of the building. If the outer wall surface is constructed of combustible material, a non-combustible plate should be fitted behind the terminal projecting 25mm beyond the external edges of the terminal.

### 3.4.5 Terminal Locations.

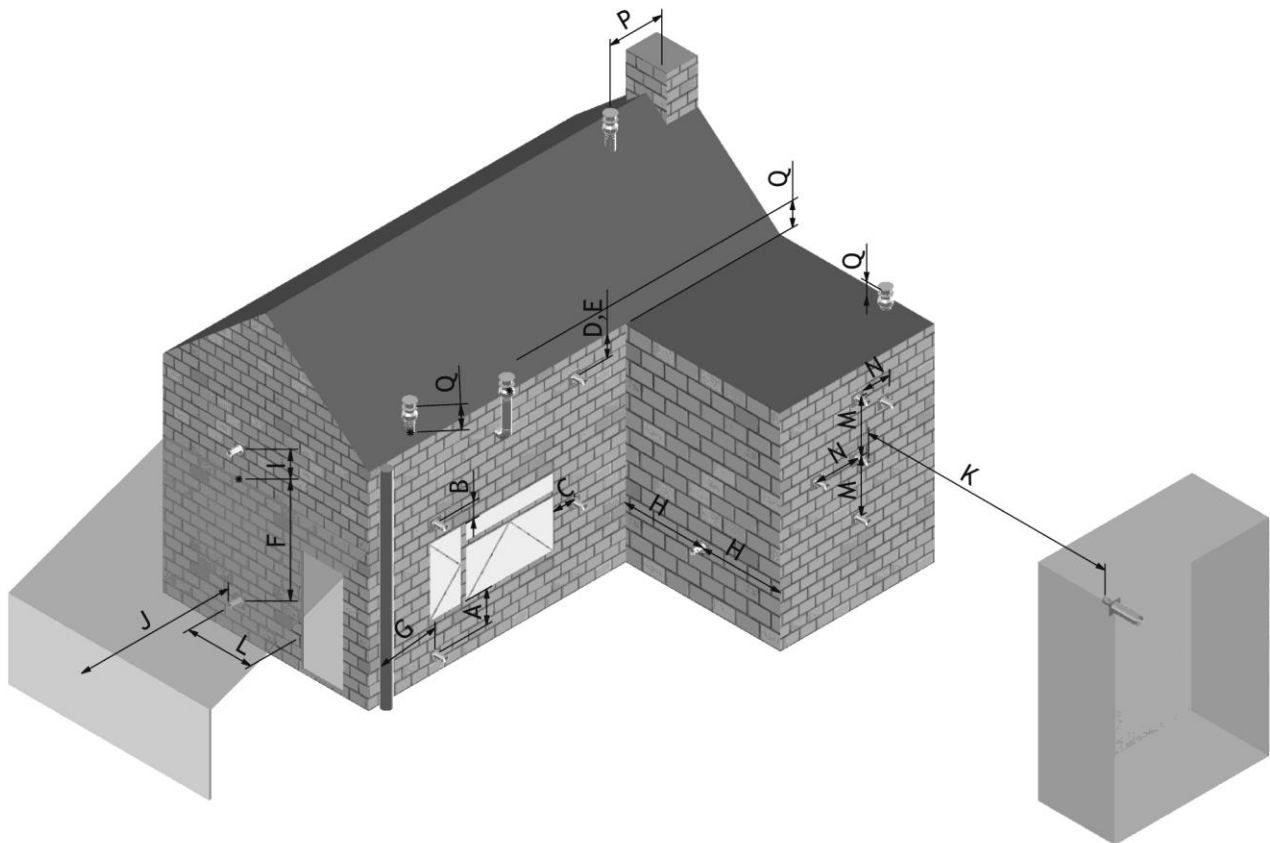

Dimension	Terminal Position	Distance (mm)
A*	Directly below an opening, air brick, opening window etc.	600
B	Above an opening, air brick, opening window etc.	300
C	Adjacent to an opening, air brick, opening window etc.	400
D	Below gutters, soil pipes or drain pipes	300
E	Below eaves	300
F	Below balconies of car port roof	600
G	From a vertical drain pipe or soil pipe	300
H	From an internal or external corner	600
I	Above ground roof or balcony level	300
J	From a surface facing the terminal	600
K	From a terminal facing the terminal	600
L	From an opening in the car port (e.g. door , window into the dwelling)	1200
M	Vertically from a terminal on the same wall	1500
N	Horizontally from a terminal on the same wall	300
P	From a vertical structure on the roof	600
Q	Above intersection with roof	150

\* In addition, the terminal should not be nearer than 300mm to an opening in the building fabric formed for the purpose of accommodating a built in element such as a window frame.

### 3.4.6 Horizontal Wall Vent Termination type C<sub>11</sub>

Flue sizing: Ø100/150 Connector on Appliance for Metaloterm US concentric flue system.  
 Ø100/150 Adaptor for Poujoulat PGI or Muelink & Grol concentric flue systems.  
 Ø100/150 Maybe used Through-out

Flue Terminal: Ø100/150

Maximum pipe extension, for outside wall (H) = 1 X Vertical Pipe Rise (V).

Maximum Permissible run (H) see table below.

Vertical Flue Rise (V) metres	Max. Horizontal Flue Run, (H) m for Ø100/150 flue
0.5	0.5
1	1
1.5	1.5
2	2
2.5	2.5
3	3
3.5	3.5
4	4
4.5	4.5
5	5
5.5	5.5
6.5	6.5
7	7
7.5 and over	7.5

Minimum Vertical Flue Height: 0.5m

Flue Restrictors to be fitted:

- Ø100/150 Vertical Rise < 2m, No Restriction.
- Ø100/150 Vertical Rise = 2 - 5m, 10mm Restriction.
- Ø100/150 Vertical Rise = 5 - 7m, 15mm Restriction.
- Ø100/150 Vertical Rise > 7m, No Restriction.

### 3.4.7 Vertical Roof Vent Termination C<sub>31</sub>

Flue sizing:                    Ø100/150 Connector on Appliance for Metaloterm US concentric flue system.  
   Ø100/150 Adaptor for Poujoulat PGI or Muelink & Grol concentric flue systems.  
   Ø100/150 Maybe used Through-out

Flue Terminal:                USDVC2 10

Minimum Vertical Flue Height: 0.5m  
Maximum Vertical Flue Height: 15m

Flue calculations when using elbows (0-90° permissible), total flue length maximum = 15m and each bend will equate to ½m, Vertical rise (V) must be at least twice the Horizontal run (R), i.e.  $V=2H$  (or  $H/V \leq 1/2$ ).

Flue Restrictors to be fitted:

- Ø100/150 Vertical Rise < 2m, 0mm Restriction.
- Ø100/150 Vertical Rise = 2-5m, 10mm Restriction.
- Ø100/150 Vertical Rise = 5-7m, 15mm Restriction.
- Ø100/150 Vertical Rise > 7m, 0mm Restriction.



### *3.5 Fuel Bed Arrangements.*

When arranging the Media into the Firebed, it is important that the Pilot area is kept clear and that no Media enters the Pilot shield. The Pilot area includes the the pilot shield and the top of the burner to the first slot inside the fence of the pilot shield.

When commissioning or servicing the Appliance Cross Lighting must be checked to ensure smooth lighting of the main burner from the Pilot Flame and smooth lighting of the effect burners from the main Burner.

3.5.1 Parallel 1.05 – Log Lay

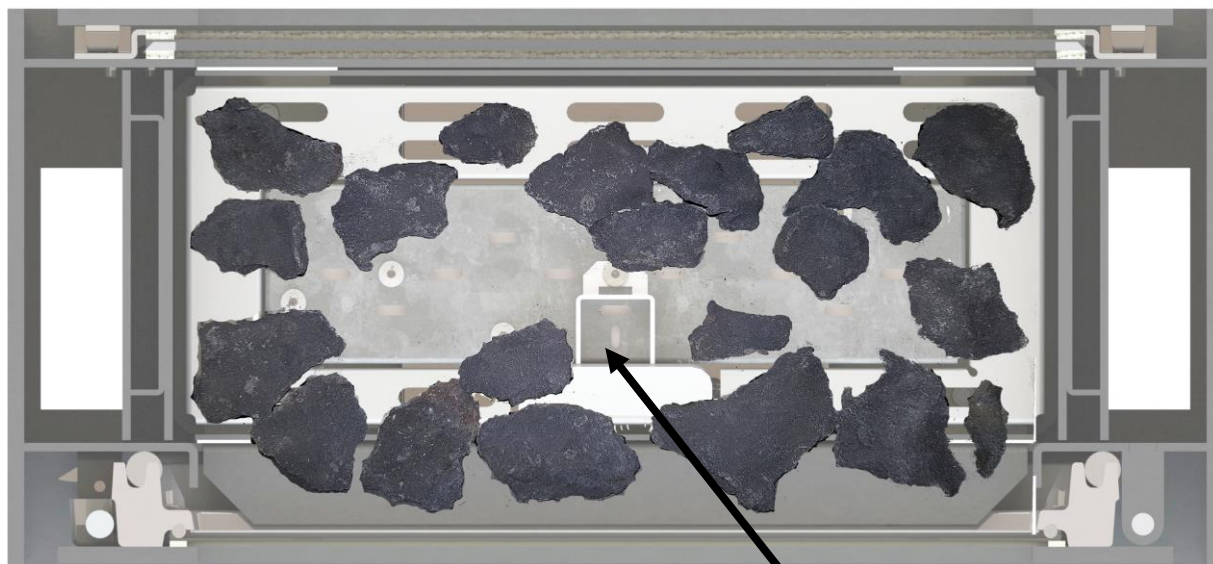
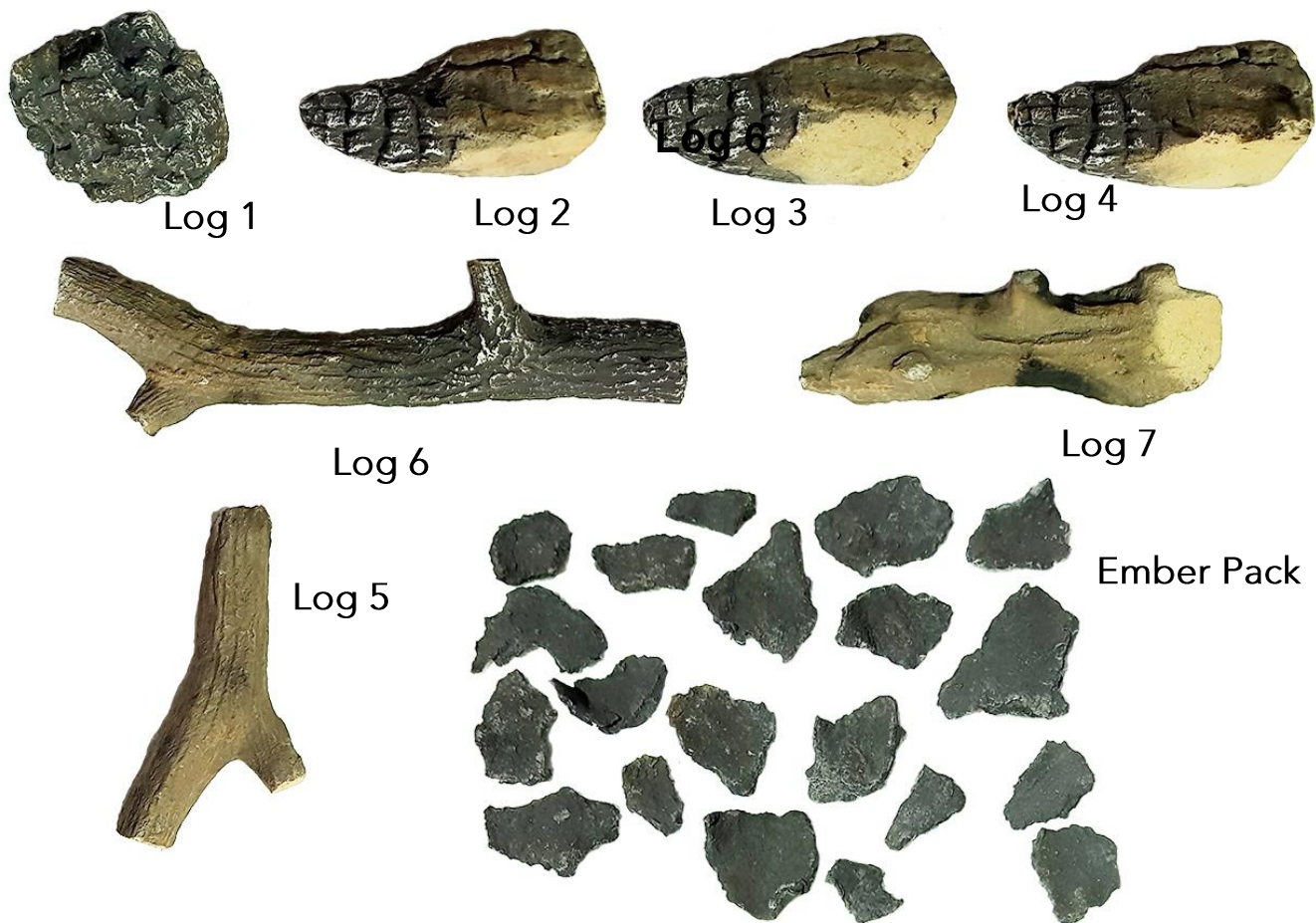

Pilot and Cross Light left clear.

Scatter the Bags of Embers over the top of the burners as shown, keeping the pilot area clear.

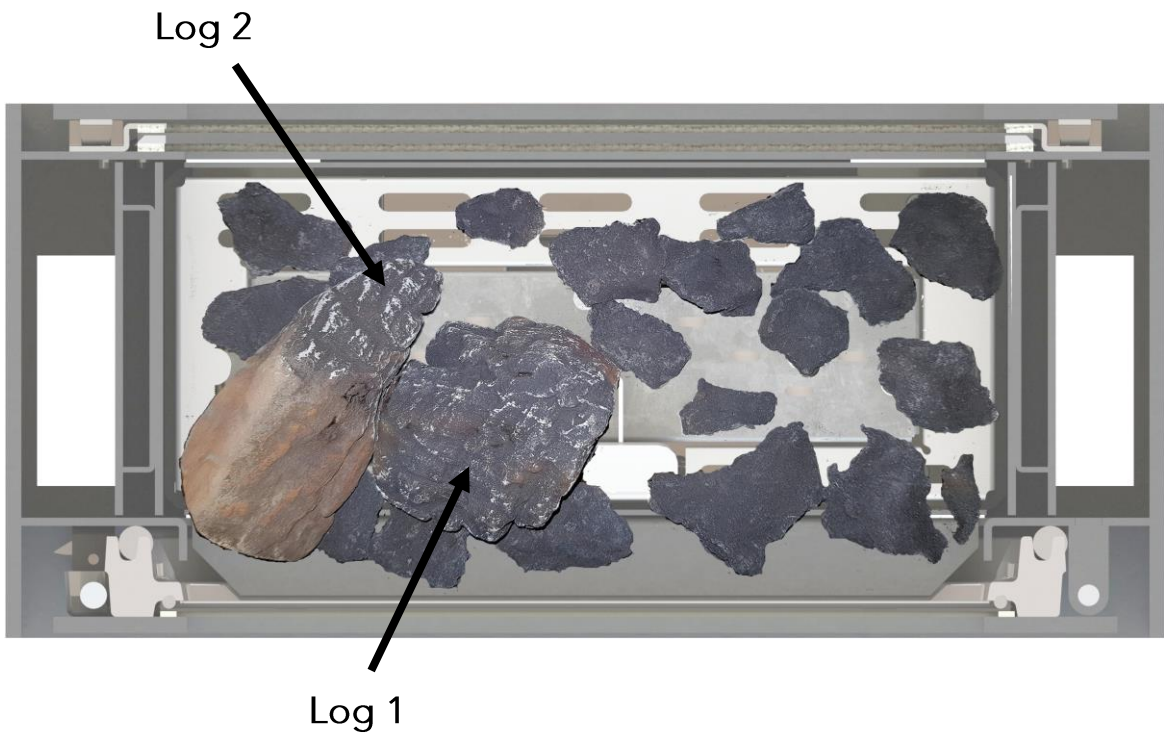

Position Logs 1 & 2 as shown in the diagram.

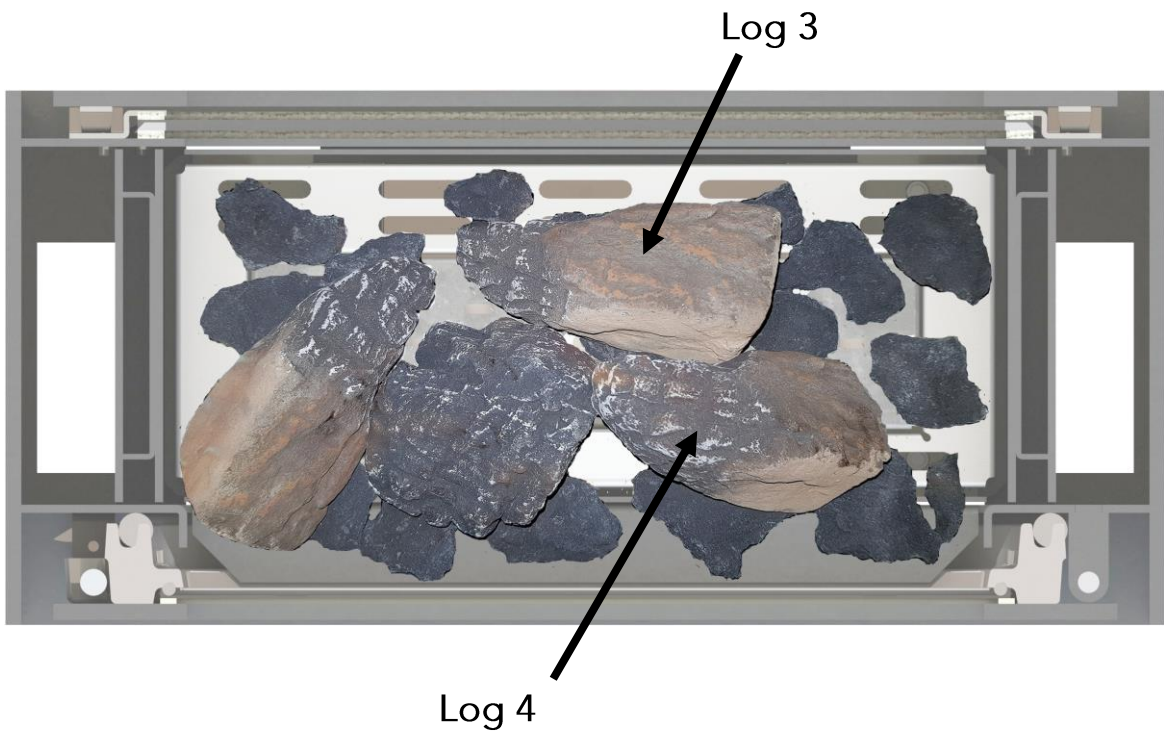

Position Logs 3 & 4 as shown in the diagram.

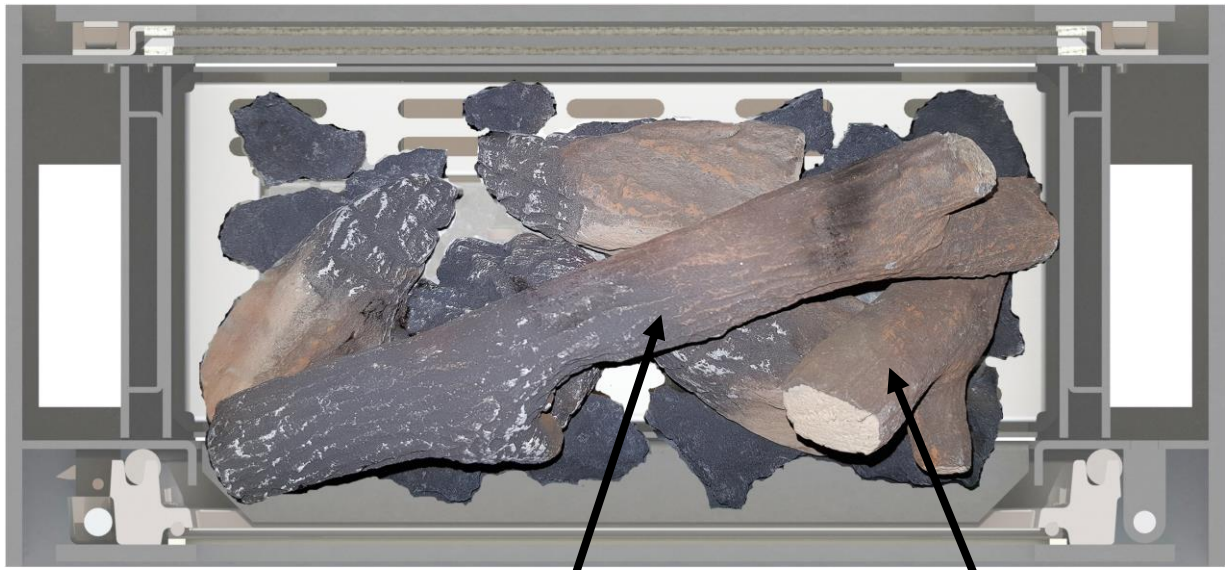

Log 6

Log 5

Position Logs 5 & 6 as shown in the diagram.



Log 7

Position the 7, as shown in the diagram.  
Finally Check the appliance for Pilot ignition and cross lighting ensuring that no material is impinging the operation of the Pilot.

### 3.5.2 White Stone Lay

Scatter the media over the Grate and Burner, keeping the pilot Clear

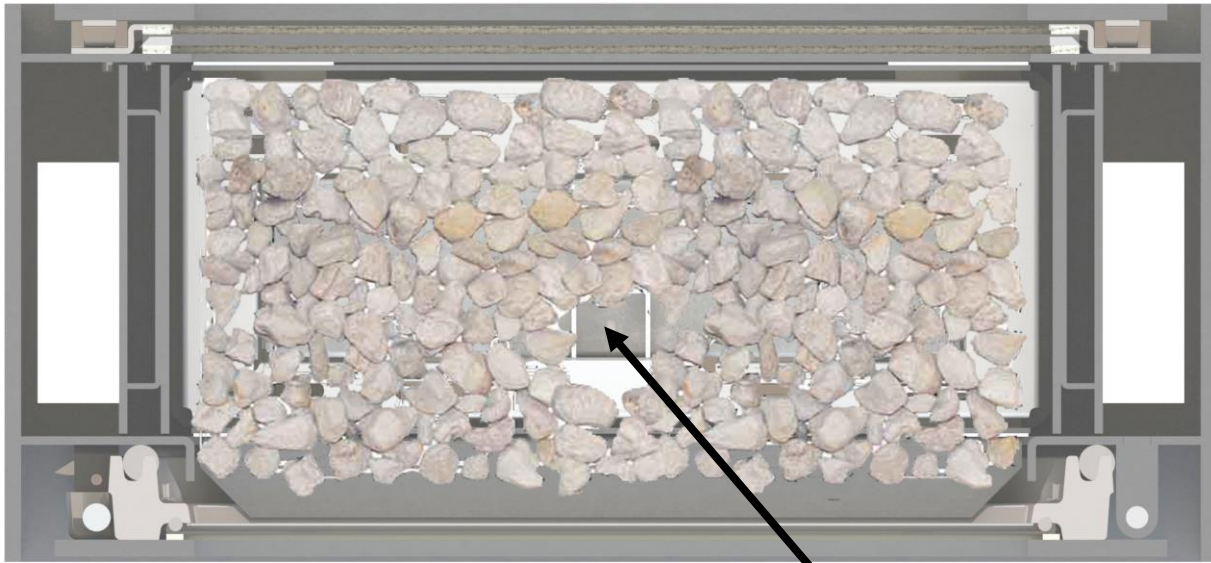

Pilot and Cross  
Light left clear.

### 3.5.3 Fire Ice Lay

Scatter the media over the Grate and Burner, keeping the pilot Clear.

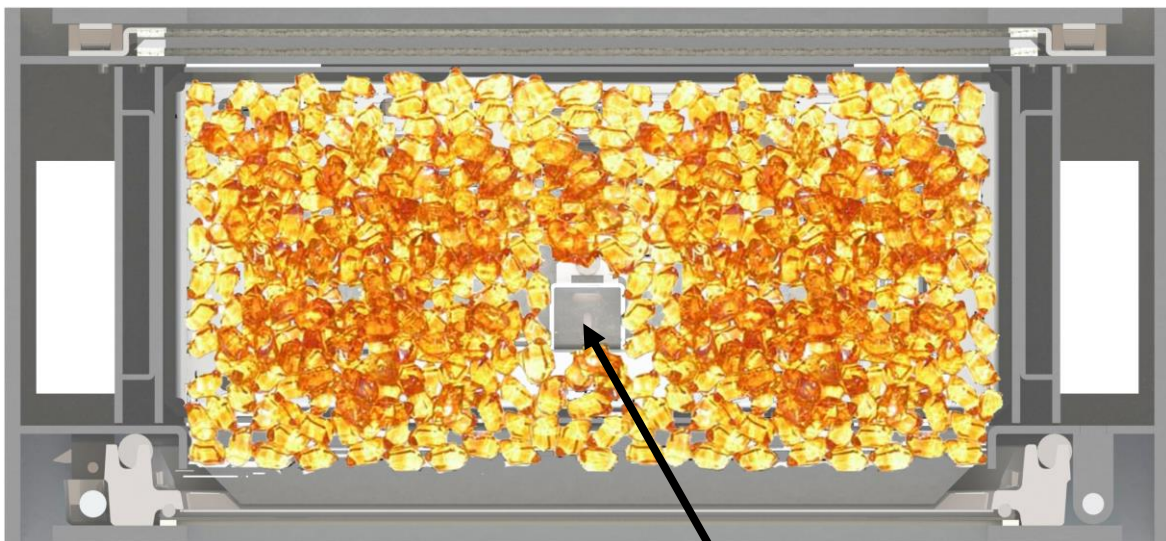

Pilot and Cross  
Light left clear.

### 3.5.4 White Pebbles Lay

Scatter the media over the Grate and Burner, keeping the pilot Clear.

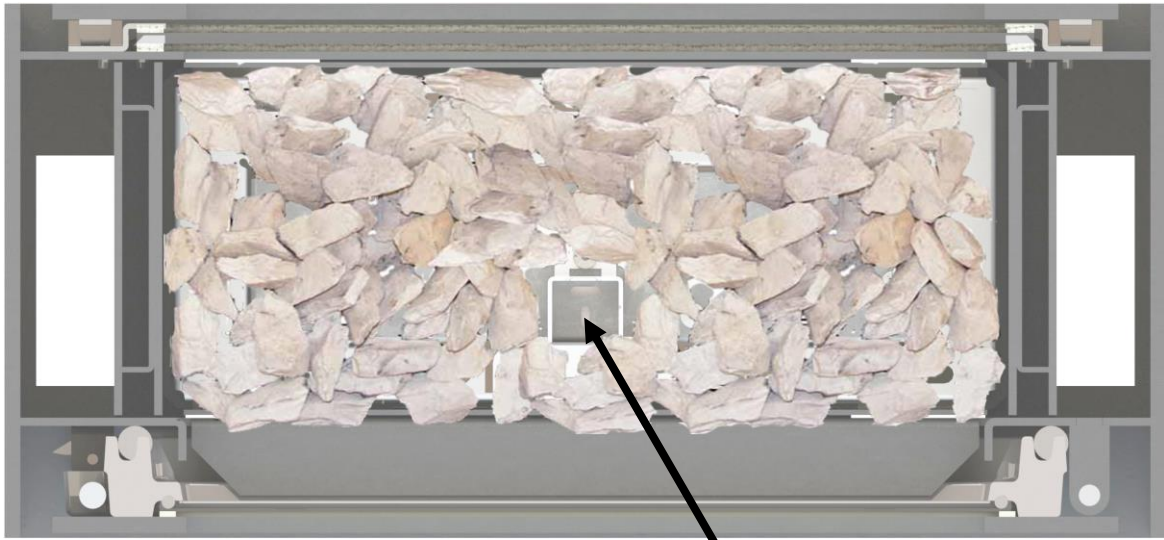

Pilot and Cross Light  
left clear.

### Lava Rock

Scatter the media over the Grate and Burner, keeping the pilot Clear.

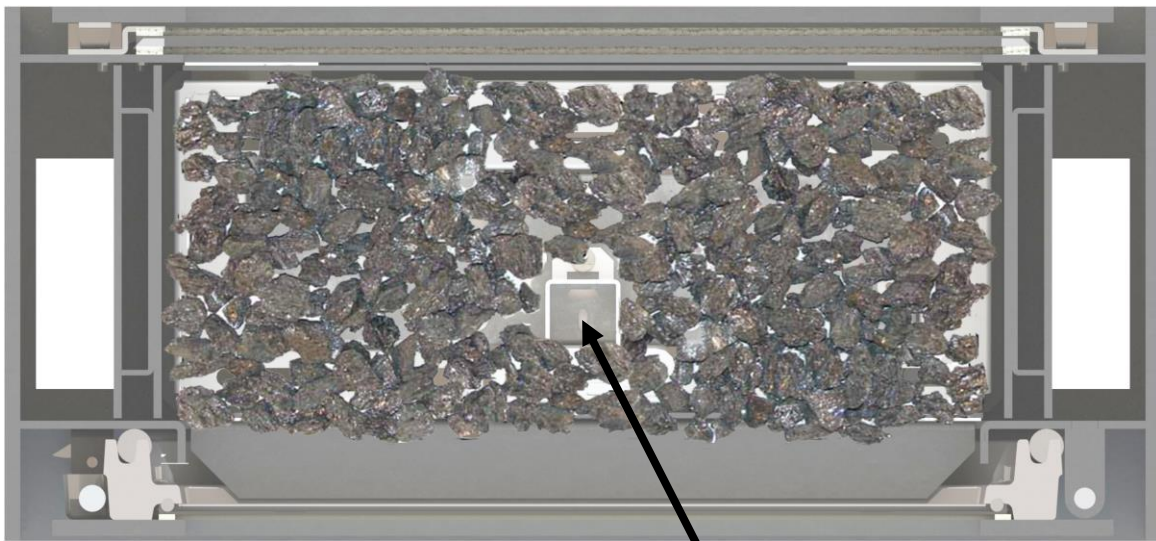

Pilot and Cross Light  
left clear.

## 3.6 Commissioning the Appliance

### 3.6.1 Pilot Ignition Check

1. Ignite the pilot light as described in the User Instructions
2. Check that the pilot flame stays alight
3. Extinguish the pilot light

### 3.6.2 Main Burner Check

1. Ignite the pilot light as described in the User Instructions
2. Turn on the main burner as described in the User Instructions
3. Check that the pilot smoothly cross-lights to the main burner and that the main burner and pilot stay alight
4. Check the operation of the "effect" burners as described in the User Instructions
5. Extinguish the appliance fully

### 3.6.3 Pressure Check

The appliance is preset to give the correct heat inputs as listed in the technical details. No further adjustment is necessary. Always check the inlet pressure and burner pressure.

1. Turn off the gas valve on the appliance
2. Release the screw on the Inlet Pressure test point on the gas valve and connect a manometer
3. Check that the measured pressure is as the prescribed supply pressure
4. Perform the test when the appliance is burning on full (inc. "effect" burners) and with only the pilot alight
5. If the pressure is low, check the gas supply pipes are too a correct sizing
6. If the pressure is too high (more than 5 mbar over) the appliance may be installed, but the gas supply company should be contacted
7. Release the screw on the Burner Pressure test point on the gas valve and connect a manometer
8. Check that the measured pressure is as detailed in the Technical details
9. The measured value should be within +/- 10% of the described value. If this is not the case, please contact the supplier.

Note: After checking the pressures and removing the manometers, the screws in the Pressure Test points must be closed, and the system must be checked for gas-tightness.

## 4. Servicing

Turn the appliance OFF and isolate the gas supply. Ensure the appliance is fully cold before attempting to start servicing the appliance. No liability can be accepted by Nestor Martin for injury caused by burning or scolding by a hot appliance.

A suggested procedure for servicing is listed below.

- A. Lay out dust sheet on flooring, mask off any special fireplace materials.
- B. Open Outer Firebox Door.
- C. Carefully remove the Ceramic components (including Embers) or Gravels
- D. Use a Vacuum cleaner to clean the top of the burners and grate
- E. Remove Grate
- F. Use the vacuum cleaner and a soft brush to clean the pilot assembly and both Injectors. It may be easier to access the Injector by removing the Throttle. Never modify or bend the Thermocouple.
- G. Clean the Window Panel.
- H. Turn on the gas supply and check for leaks, check the burners and Pilot for good condition and operation
- I. Replace Grate
- J. Replace the Firebed arrangements
- K. Close doors.
- L. Check the flue system and terminal, making sure that the terminal vent is fully clear
- M. Light the appliance and test setting pressures
- N. Check the safe operation of the appliance.

### 4.1 Cleaning the Ceramics

Remove the ceramics as detailed in A - E above.

Gently clean the ceramics in the open air, using a soft brush and a vacuum cleaner. Where necessary replace damaged components only with genuine Nestor Martin specified parts. Seal any scrap ceramics in plastic bags and dispose at proper refuse sites. When using a vacuum cleaner, it is recommended that one with a HEPA filtering system is used.

Re-fit the Firebed arrangement, re-seal the appliance and check the safe operation of the appliance.

### 4.2 Servicing the Burner

A fault finding chart is included in the appendix for the Mertik control system fitted to this appliance.

Access the Burner as detailed in A - F above.

The pilot is now clearly visible, the pilot, including the Thermocouple, can be replaced/serviced by removing raising the pilot assembly from its mounting. This is done by removing the two screws on the surface of the pilot. The fittings on the under-side of the pilot can be un-done using a 10mm spanner where appropriate.

The Main Burner Injectors can be accessed from the underside of the appliance. If the burner requires to be removed, this may be done by removing the 4 M6 fixings inside the firebox (10mm Spanner), the burner will lift out through the Firebox.

When replacing any parts use only original Nestor Martin specified parts.

### 4.3 Spare parts

For spare parts, contact your Nestor Martin dealer directly to specify the desired spare part



## 5. Technical Information

### 5.1 Countries of Use

Country	Natural	LPG
AT -Austria	I <sub>2H</sub> , G20 at 20 mbar	I <sub>3P(50)</sub> ,G31 at 50 mbar; I <sub>3B/P(50)</sub> ,G30/G31 at 50 mbar
BE -Belgium	I <sub>2E+</sub> , G20/G25 at 20/25 mbar	I <sub>3+</sub> ,G31/G31 at 28/37 mbar; I <sub>3P(37)</sub> ,G31 at 37 mbar; I <sub>3B/P(30)</sub> ,G30/G31 at 30 mbar
BG -Bulgaria	I <sub>2H</sub> , G20 at 20 mbar	I <sub>3B/P(30)</sub> ,G30/G31 at 30 mbar
CH - Switzerland	I <sub>2H</sub> , G20 at 20 mbar	I <sub>3P(50)</sub> ,G31 at 50 mbar; I <sub>3+</sub> ,G31/G31 at 28/37 mbar; I <sub>3P(37)</sub> ,G31 at 37 mbar; I <sub>3B/P(50)</sub> ,G30/G31 at 50
CY -Cyprus	I <sub>2H</sub> , G20 at 20 mbar	I <sub>3+</sub> ,G31/G31 at 28/37 mbar; I <sub>3B/P(30)</sub> ,G30/G31 at 30 mbar
CZ -Czech Republic	I <sub>2H</sub> , G20 at 20 mbar	I <sub>3P(50)</sub> ,G31 at 50 mbar; I <sub>3+</sub> ,G31/G31 at 28/37 mbar; I <sub>3P(37)</sub> ,G31 at 37 mbar; I <sub>3B/P(50)</sub> ,G30/G31 at 50
DE -Germany	I <sub>2ELL</sub> , G25 at 20 mbar; I <sub>2E</sub> , G20 at 20 mbar	I <sub>3P(50)</sub> ,G31 at 50 mbar; I <sub>3B/P(50)</sub> ,G30/G31 at 50
DK -Denmark	I <sub>2H</sub> , G20 at 20 mbar	I <sub>3B/P(30)</sub> ,G30/G31 at 30 mbar
EE -Estonia	I <sub>2H</sub> , G20 at 20 mbar	I <sub>3B/P(30)</sub> ,G30/G31 at 30 mbar
ES -Spain	I <sub>2H</sub> , G20 at 20 mbar	I <sub>3+</sub> ,G31/G31 at 28/37 mbar; I <sub>3P(37)</sub> ,G31 at 37 mbar
FI -Finland	I <sub>2H</sub> , G20 at 20 mbar	I <sub>3P(30)</sub> ,G31 at 30 mbar; I <sub>3B/P(30)</sub> ,G30/G31 at 30 mbar
FR -France	I <sub>2E+</sub> , G20/G25 at 20/25 mbar	I <sub>3+</sub> ,G31/G31 at 28/37 mbar; I <sub>3P(37)</sub> ,G31 at 37 mbar; I <sub>3B/P(30)</sub> ,G30/G31 at 30 mbar; I <sub>3B/P(50)</sub> ,G30/G31 at 50
GB -United Kingdom	I <sub>2H</sub> , G20 at 20 mbar	I <sub>3+</sub> ,G31/G31 at 28/37 mbar; I <sub>3P(37)</sub> ,G31 at 37 mbar; I <sub>3B/P(30)</sub> ,G30/G31 at 30 mbar
GR -Greece	I <sub>2H</sub> , G20 at 20 mbar	I <sub>3+</sub> ,G31/G31 at 28/37 mbar; I <sub>3P(37)</sub> ,G31 at 37 mbar; I <sub>3B/P(30)</sub> ,G30/G31 at 30 mbar
HU -Hungary		I <sub>3B/P(30)</sub> ,G30/G31 at 30 mbar
HR -Croatia	I <sub>2H</sub> , G20 at 20 mbar	I <sub>3P(37)</sub> ,G31 at 37 mbar; I <sub>3B/P(30)</sub> ,G30/G31 at 30 mbar
IE -Ireland	I <sub>2H</sub> , G20 at 20 mbar	I <sub>3+</sub> ,G31/G31 at 28/37 mbar; I <sub>3P(37)</sub> ,G31 at 37 mbar
IS -Iceland		
IT -Italy	I <sub>2H</sub> , G20 at 20 mbar	I <sub>3+</sub> ,G31/G31 at 28/37 mbar; I <sub>3P(37)</sub> ,G31 at 37 mbar; I <sub>3B/P(30)</sub> ,G30/G31 at 30 mbar
LT -Lithuania	I <sub>2H</sub> , G20 at 20 mbar	I <sub>3+</sub> ,G31/G31 at 28/37 mbar; I <sub>3P(37)</sub> ,G31 at 37 mbar; I <sub>3B/P(30)</sub> ,G30/G31 at 30 mbar
LU -Luxembourg	I <sub>2E</sub> , G20 at 20 mbar	
LV -Latvia	I <sub>2H</sub> , G20 at 20 mbar	
MT -Malta		I <sub>3B/P(30)</sub> ,G30/G31 at 30 mbar
NL -The Netherlands	I <sub>2</sub> (43.46-45.3 MJ/m <sup>3</sup> ) 25 mbar	I <sub>3P(50)</sub> ,G31 at 50 mbar; I <sub>3P(30)</sub> ,G31 at 30 mbar; I <sub>3P(37)</sub> ,G31 at 37 mbar; I <sub>3B/P(30)</sub> ,G30/G31 at 30 mbar
NO -Norway	I <sub>2H</sub> , G20 at 20 mbar	I <sub>3B/P(30)</sub> ,G30/G31 at 30 mbar
PL -Poland	I <sub>2E</sub> , G20 at 20 mbar	I <sub>3P(37)</sub> ,G31 at 37 mbar
PT -Portugal	I <sub>2H</sub> , G20 at 20 mbar	I <sub>3+</sub> ,G31/G31 at 28/37 mbar; I <sub>3P(37)</sub> ,G31 at 37 mbar
RO -Romania	I <sub>2E</sub> , G20 at 20 mbar	I <sub>3P(30)</sub> ,G31 at 30 mbar; I <sub>3B/P(30)</sub> ,G30/G31 at 30 mbar
SE - Sweden	I <sub>2H</sub> , G20 at 20 mbar	I <sub>3B/P(30)</sub> ,G30/G31 at 30 mbar
SL -Slovenia	I <sub>2H</sub> , G20 at 20 mbar	I <sub>3+</sub> ,G31/G31 at 28/37 mbar; I <sub>3P(37)</sub> ,G31 at 37 mbar; I <sub>3B/P(30)</sub> ,G30/G31 at 30 mbar
SK -Slovakia	I <sub>2H</sub> , G20 at 20 mbar	I <sub>3P(50)</sub> ,G31 at 50 mbar; I <sub>3+</sub> ,G31/G31 at 28/37 mbar; I <sub>3P(37)</sub> ,G31 at 37 mbar; I <sub>3B/P(30)</sub> ,G30/G31 at 30 mbar; I <sub>3B/P(50)</sub> ,G30/G31 at 50
TR -Turkey	I <sub>2H</sub> , G20 at 20 mbar	I <sub>3+</sub> ,G31/G31 at 28/37 mbar; I <sub>3P(37)</sub> ,G31 at 37 mbar; I <sub>3B/P(30)</sub> ,G30/G31 at 30 mbar

## 5.2 Technical Data

Product Identification Number : 0359CR0001255

### Nestor Martin THS15 Gas

Gas type		G20 l2H,l2E	G20/G25 l2E+	G20/G25 l2ELL	G25/G25.3 l2L,l2EK
Supply Pressure	mbar	20	20/25	20	25
Nominal Heat Input Gross (Hs)	kW	8	8/7.3	8/6.5	7.3
Nominal Heat Input Nett (Hi)	kW	7.2	7.2/6.6	7.2/6.6	6.6
Consumption	m <sup>3</sup> /hr	0.739	0.739/0.788	0.739/0.706	0.788
Burner Pressure (hot)	mbar	17.4	17.4/21.7	17.4/17.6	21.7
Injector Marking	480				
Pilot	446.1385.24				
Efficiency Class	1				
Nox Class	5				

### Nestor Martin THS15 LPG

Gas type		G30/G31		G31	
		l3B/P(30/50)	l3+	l3P(37,50)	l3P(30)
Supply Pressure	mbar	30/50	28-30/37	37/50	30
Nominal Heat Input Gross (Hs)	kW	5.5	5.5	5.5	5
Nominal Heat Input Nett (Hi)	kW	5.1	5.1	5.1	4.6
Consumption	m <sup>3</sup> /hr	0.133	0.133	0.173	0.147
Burner Pressure (hot)	mbar	29.8	29.8	36	29
Injector Marking	140				
Pilot	446.1385.44				
Efficiency Class	1				
Nox Class	5				

## 5.3 Dimensions

THS15

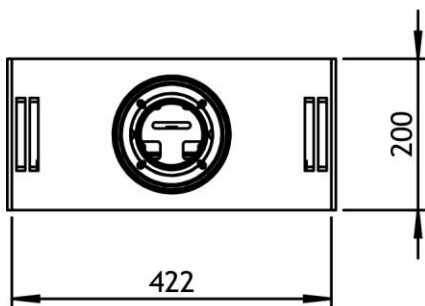
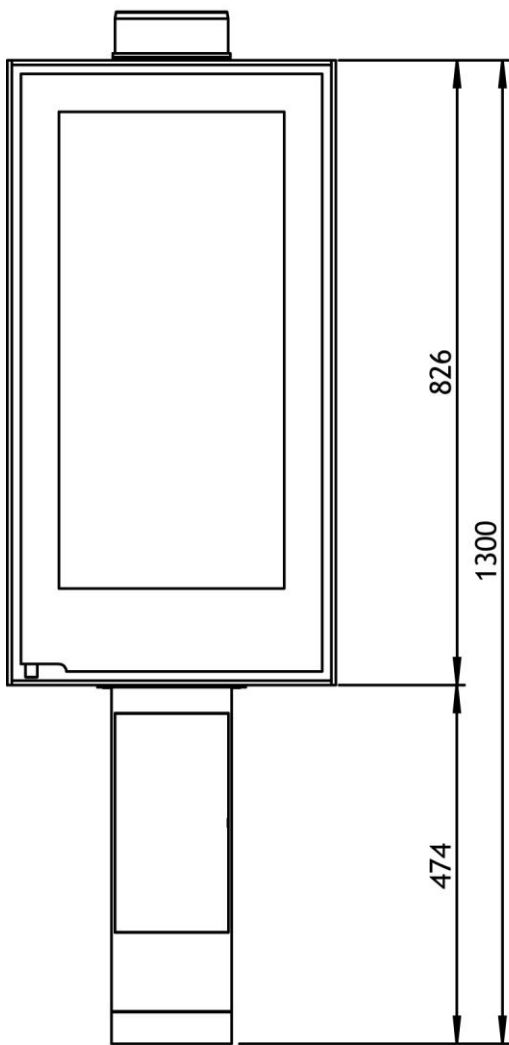

Appendix 1 Mertik Fault Finding Chart.

FUNCTION	POSSIBLE CAUSE	REMEDY
<b>1. TOUCH PAD/ WALL SWITCH/ SWITCH PANEL START:</b> Press ON Button, Touch pad/wall switch works.	No →	Bent pin. Touch pad, switch panel or cable not operating properly. Straighten pin, replace touch pad, switch and/or cable.
<b>1. HANDSET START:</b> Press both buttons to start ignition (IGN) sequence. Beep will occur each second.	No →	Transmitter batteries low. Replace transmitter batteries. 9V quality alkaline recommended.
		Receiver batteries low. Replace receiver batteries with 1.5V "AA" quality alkaline batteries.
		Optional mains adapter not operating properly. Check mains adapter.
		Check coding of transmitter and receiver. (Initial sync.) Learn new code (reset). See label on receiver.
		Transmitter distance limited. 1. Straighten the antenna. 2. Replace receiver. See wiring diagram, pg. 6, GV60_II_EN-11.2008.
		Touch pad, switch panel, or cable not operating properly (in older versions, nonfunctional touch pad blocks the transmitter). Unplug or replace touchpad, switch panel, or cable. See wiring diagram, pg. 6, GV60_II_EN-11.2008.
		Blown fuse (in older versions only). Replace receiver. See wiring diagram, pg. 6, GV60_II_EN-11.2008.
OK ↓		
<b>2.</b> Magnet unit is energized (audible thud to detect functionality).	No →	No beep → Impulse magnet not operating properly. Replace gas valve. See "Installation Instructions" pg. 3, GV60_II_EN-11.2008.
	No →	3 short beeps → Low batteries. Replace receiver batteries with 1.5V "AA" quality alkaline batteries.
	No →	1 long beep → ON/OFF switch in OFF position. Switch to ON.
		8-wire cable Off/not operating properly. Check 8-wire cable.
		SW-cable disconnected. Check cable connection. See figure 1 on page 3.
		Motor not operating properly. Replace gas valve. See "Installation Instructions" pg. 3, GV60_II_EN-11.2008.
	Micro switch not operating properly. Replace gas valve. See "Installation Instructions" pg. 3, GV60_II_EN-11.2008.	
OK ↓		

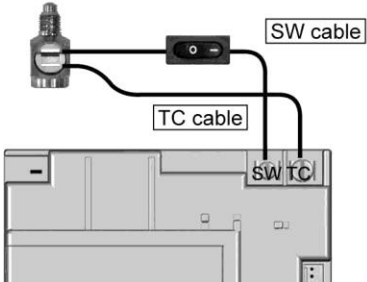
FUNCTION	POSSIBLE CAUSE	REMEDY	
<p>3.</p> <p>Spark will occur each second.</p> <p>OK ↓</p>	No →	<p>Ignition components not operating properly.</p> <p>Check connection between cable &amp; IGN-electrode. See wiring diagram pg. 6, GV60_II_EN-11.2008.</p> <p>Check IGN-electrode spark gap. See wiring diagram pg. 6, GV60_II_EN-11.2008</p> <p>Check IGN-electrode. See wiring diagram pg. 6, GV60_II_EN-11.2008.</p> <p>Check IGN-cable for damage. See wiring diagram pg. 6, GV60_II_EN-11.2008.</p> <p>Increase distance between IGN-cable and all metal parts. Shorten IGN-cable if possible or cover, e.g. silicon hose. See wiring diagram pg. 6, GV60_II_EN-11.2008.</p>	
	No →	<p>IGN-sequence stops, no pilot flame. No reaction to transmitter command. (Controller crashes.)</p> <p>Press RESET button. See "Setting the Electronics Code" pg. 2, GV60_OI_EN-11.2008.</p> <p>Add ground wire between pilot burner and valve. See wiring diagram pg. 6, GV60_II_EN-11.2008.</p> <p>Do not coil the IGN-cable.</p> <p>Shorten IGN-cable if possible (no longer than 900 mm). See wiring diagram pg. 6, GV60_II_EN-11.2008.</p>	
	No →	<p>IGN-sequence stops, no pilot flame. Transmitter command is possible.</p> <p>Replace receiver batteries with 1.5V "AA" quality alkaline batteries.</p>	
	<p>4.</p> <p>Pilot lit.</p> <p>OK ↓</p>	No →	<p>TC- and SW-cable reversed.</p> <p>Check connection of cable to receiver and interrupter. See figure 1.</p>
			<p>Magnet unit not operating properly.</p> <p>Replace gas valve or (magnet unit [CE only]). See "Installation Instructions" pg. 3, GV60_II_EN-11.2008</p>
			<p>Short between interrupter and SW-cable.</p> <p>Check connection to interrupter.</p>
			<p>No gas (magnet unit drops after 30 second audible count).</p> <p>Check gas supply.</p>
	 <p>Figure 1</p>		
	<p>5.</p> <p>Sparkling stops after pilot is lit.</p> <p>OK ↓</p>	No →	<p>Short between interrupter and TC-cable.</p> <p>Check connection to interrupter. See figure 1.</p>
		<p>Electronic measuring amplifier defective.</p> <p>Replace Receiver. See wiring diagram pg. 6, GV60_II_EN-11.2008.</p>	

FUNCTION	POSSIBLE CAUSE	REMEDY
----------	----------------	--------

<b>6.</b>	<div style="border: 1px solid black; padding: 5px; min-height: 150px;">                     Motor turns to main gas and pilot stays lit.                 </div>	No →  Magnet unit drops (audible sound).          No →	<table border="1" style="width:100%; border-collapse: collapse;"> <tr> <td style="padding: 2px;">Resistance in thermo current circuit too high.</td> <td style="padding: 2px;">Check cable in thermo-current circuit. See wiring diagram pg. 6, GV60_II_EN-11.2008.</td> </tr> <tr> <td style="padding: 2px;">Not enough heat on thermocouple.</td> <td style="padding: 2px;">Check position of pilot to thermocouple and intensity of pilot flame.</td> </tr> <tr> <td style="padding: 2px;">Low voltage from thermocouple.</td> <td style="padding: 2px;">Replace thermocouple Do not overtighten (hand tight +1/4 turn max). See "Thermo Circuit" pg. 5, GV60_II_EN-11.2008.</td> </tr> <tr> <td style="padding: 2px;">Short because thermocouple end is damaged or not centered.</td> <td style="padding: 2px;">Replace thermocouple. Do not overtighten (hand tight +1/4 turn max). See "Thermo Circuit" pg. 5, GV60_II_EN-11.2008.</td> </tr> </table> <table border="1" style="width:100%; border-collapse: collapse;"> <tr> <td style="padding: 2px;">IGN-sequence stops. No reaction to transmitter command. (Controller crashes.)</td> <td style="padding: 2px;">Press RESET button. See "Setting the Electronics Code" pg. 2, GV60_OI_EN-11.2008.</td> </tr> <tr> <td style="padding: 2px;"></td> <td style="padding: 2px;">Add ground wire between pilot burner and valve. See wiring diagram pg. 6, GV60_II_EN-11.2008.</td> </tr> <tr> <td style="padding: 2px;"></td> <td style="padding: 2px;">Do not coil the IGN-cable.</td> </tr> <tr> <td style="padding: 2px;"></td> <td style="padding: 2px;">Shorten IGN-cable if possible (no longer than 900 mm). See wiring diagram pg. 6, GV60_II_EN-11.2008.</td> </tr> </table>	Resistance in thermo current circuit too high.	Check cable in thermo-current circuit. See wiring diagram pg. 6, GV60_II_EN-11.2008.	Not enough heat on thermocouple.	Check position of pilot to thermocouple and intensity of pilot flame.	Low voltage from thermocouple.	Replace thermocouple Do not overtighten (hand tight +1/4 turn max). See "Thermo Circuit" pg. 5, GV60_II_EN-11.2008.	Short because thermocouple end is damaged or not centered.	Replace thermocouple. Do not overtighten (hand tight +1/4 turn max). See "Thermo Circuit" pg. 5, GV60_II_EN-11.2008.	IGN-sequence stops. No reaction to transmitter command. (Controller crashes.)	Press RESET button. See "Setting the Electronics Code" pg. 2, GV60_OI_EN-11.2008.		Add ground wire between pilot burner and valve. See wiring diagram pg. 6, GV60_II_EN-11.2008.		Do not coil the IGN-cable.		Shorten IGN-cable if possible (no longer than 900 mm). See wiring diagram pg. 6, GV60_II_EN-11.2008.	<div style="text-align: center; margin-bottom: 10px;">                         OK ↓                     </div>
Resistance in thermo current circuit too high.	Check cable in thermo-current circuit. See wiring diagram pg. 6, GV60_II_EN-11.2008.																			
Not enough heat on thermocouple.	Check position of pilot to thermocouple and intensity of pilot flame.																			
Low voltage from thermocouple.	Replace thermocouple Do not overtighten (hand tight +1/4 turn max). See "Thermo Circuit" pg. 5, GV60_II_EN-11.2008.																			
Short because thermocouple end is damaged or not centered.	Replace thermocouple. Do not overtighten (hand tight +1/4 turn max). See "Thermo Circuit" pg. 5, GV60_II_EN-11.2008.																			
IGN-sequence stops. No reaction to transmitter command. (Controller crashes.)	Press RESET button. See "Setting the Electronics Code" pg. 2, GV60_OI_EN-11.2008.																			
	Add ground wire between pilot burner and valve. See wiring diagram pg. 6, GV60_II_EN-11.2008.																			
	Do not coil the IGN-cable.																			
	Shorten IGN-cable if possible (no longer than 900 mm). See wiring diagram pg. 6, GV60_II_EN-11.2008.																			

<b>7.</b>	<div style="border: 1px solid black; padding: 5px; min-height: 30px;">                     Main burner is lit.                 </div>	No →	<table border="1" style="width:100%; border-collapse: collapse;"> <tr> <td style="padding: 2px;">Manual knob in "MAN" position.</td> <td style="padding: 2px;">Turn manual knob to "ON" position (positive latch is required). See "Manual Operation" pg. 4, GV60_OI_EN-11.2008.</td> </tr> </table>	Manual knob in "MAN" position.	Turn manual knob to "ON" position (positive latch is required). See "Manual Operation" pg. 4, GV60_OI_EN-11.2008.	<div style="text-align: center;">                         OK ↓                     </div>
Manual knob in "MAN" position.	Turn manual knob to "ON" position (positive latch is required). See "Manual Operation" pg. 4, GV60_OI_EN-11.2008.					

<b>8.</b>	<div style="border: 1px solid black; padding: 5px; min-height: 30px;">                     Main burner stays lit.                 </div>	No →	<table border="1" style="width:100%; border-collapse: collapse;"> <tr> <td style="padding: 2px;">Too much draft at pilot (poor flame impingement of thermo-couple).</td> <td style="padding: 2px;">Check installation. See "Pilot Flame Adjustment" pg. 7, GV60_II_EN-11.2008.</td> </tr> </table>	Too much draft at pilot (poor flame impingement of thermo-couple).	Check installation. See "Pilot Flame Adjustment" pg. 7, GV60_II_EN-11.2008.	<div style="text-align: center;">                         OK ↓                     </div>
Too much draft at pilot (poor flame impingement of thermo-couple).	Check installation. See "Pilot Flame Adjustment" pg. 7, GV60_II_EN-11.2008.					

<b>9.</b>	<div style="border: 1px solid black; padding: 5px; min-height: 30px;">                     Magnet unit drops while motor turns. 3 beeps.                 </div>	No →	<table border="1" style="width:100%; border-collapse: collapse;"> <tr> <td style="padding: 2px;">Low batteries.</td> <td style="padding: 2px;">Replace receiver batteries with 1.5V "AA" quality alkaline batteries.</td> </tr> </table>	Low batteries.	Replace receiver batteries with 1.5V "AA" quality alkaline batteries.	
Low batteries.	Replace receiver batteries with 1.5V "AA" quality alkaline batteries.					

<div style="border: 1px solid black; padding: 5px; min-height: 30px;">                     System can be switched OFF via the electronics.                 </div>	No →	<div style="border: 1px solid black; padding: 5px; min-height: 30px;">                     System CAN be switched OFF via ON/OFF switch.                 </div>	No →	<table border="1" style="width:100%; border-collapse: collapse;"> <tr> <td style="padding: 2px;">Short in interrupter between TC- and SW- cable.</td> <td style="padding: 2px;">Check connection to interrupter block. See wiring diagram pg. 6, GV60_II_EN-11.2008.</td> </tr> </table>	Short in interrupter between TC- and SW- cable.	Check connection to interrupter block. See wiring diagram pg. 6, GV60_II_EN-11.2008.
Short in interrupter between TC- and SW- cable.	Check connection to interrupter block. See wiring diagram pg. 6, GV60_II_EN-11.2008.					
YES ↓ OK		YES ↓ OK		<table border="1" style="width:100%; border-collapse: collapse;"> <tr> <td style="padding: 2px;">Replace gas valve (magnet unit [CE only]). See "Installation Instructions" pg. 3, GV60_II_EN-11.2008.</td> </tr> </table>	Replace gas valve (magnet unit [CE only]). See "Installation Instructions" pg. 3, GV60_II_EN-11.2008.	
Replace gas valve (magnet unit [CE only]). See "Installation Instructions" pg. 3, GV60_II_EN-11.2008.						

**NESTOR  
MARTIN**

**hergom**

Made in Belgium by

SCJ Stove Works  
Rue du lion, 5  
5660 Couvin  
Belgium